



**5M60M8690**  
**38cm Built-in microwave**  
**Dark Steel / Glas**

**Performance, consumption**

- Voltage: 230V
- Total connected load: 2300W
- Microwave output: 5 levels max. 900W
- Grill output: 1100 W
- Hot air output: 2300 W

**Oven type, heating mode**

- Built-in microwave with 3 heating modes
- Hot air
- Convection grill
- Defrost function
- Microwave with 5 power settings: - 100W, 300W, 500W, 700W, 900W - Combi mode
- Quick cooking function
- Automatic programmes

**Design, Comfort**

- Smart Slider
- Touch Control
- Digital Display (white LED)
- Oven capacity: 34 L
- Interior lighting
- Safety shut-off
- Removable door for easy cleaning
- Child lock

**Dimensions H x W x D**

- Unit dimensions: 382 x 595 x 492 mm
- Installation dimensions: 380 x 560 x 550 mm
- Front panel height 82 mm
- Unit dimensions (packed) 660 x 582 x 466 mm
- Net weight (kg): 24.7
- Gross weight (kg): 27.6

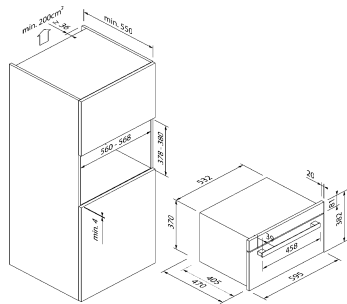

EAN-Nr.: 4251003108279

**Equipment features:**

- Front colour: Darksteel and black glass
- Design: Built-in appliance
- Front panel material: Stainless steel +glass
- Door material: Stainless steel +glass
- Net interior volume (l): 34L
- Interior: Stainless steel
- Number of lights: 1
- Length of connection cable (cm): 100

**Consumption and connection values:**

- Electrical connected load (W): 2300 W
- Voltage (V): 230
- Frequency (Hz): 50
- Plug type: Schuko
- Energy source: Electric
- Approval certificates: GS, CE

**Accessories:**

- 1 x glass turntable
- 2 x combi grate