

**BLAUPUNKT**

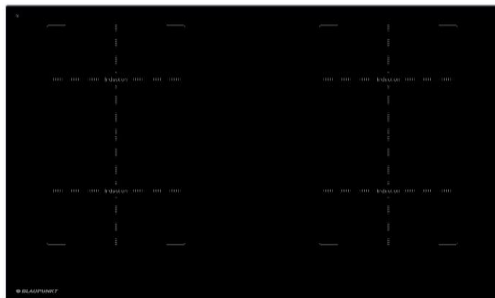

**5II84353**  
**80cm Induction hob, self-sufficient**

**Power / Consumption**

- Voltage: 220 - 240 V
- Total connected load 7.4 kW
- 4 induction cooking zones with booster:
- 4 x 20.0 x 21.0 cm with 2.1 kW (3.0 kW)

**Equipment / Comfort**

- Aluminium frame
- 2 x combi induction
- Booster for all induction cooking zones
- Start-up boost
- Smart Slider
- Touch control
- 10 power levels
- Timer simultaneously for each cooking zone
- Egg timer
- Child lock
- Pause function
- Recall - repeat last settings
- Keep warm function (~70°C)
- Demo mode
- Digital display of cooking levels (red)
- Residual heat display for each cooking zone
- Overflow detection
- Automatic safety shut-off
- Quick start function
- Pot detection
- Multicontrol

**Dimensions**

- Unit dimensions: (H/W/D) 58 x 784 x 524 mm
- Installation dimensions: (H/W/D) 52 x 750 x 500 mm
- Min. worktop thickness: 16 mm

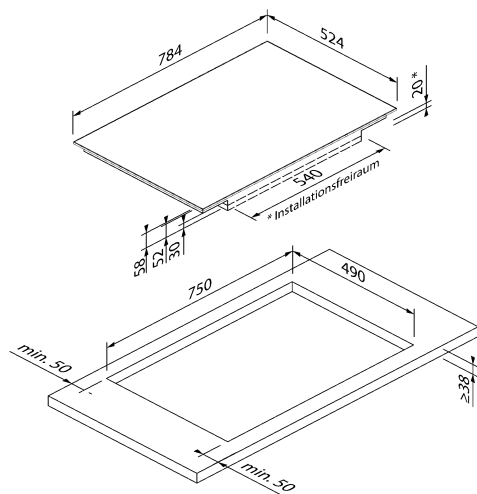

EAN-Nr.: 4251003108156

**Special accessories:**

**Available colour variants:**

**Accessories**

**Technical features:**

Appliance type: Glass ceramic hob  
Design: Built-in appliance - support Energy source: Electric

Number of cooking zones that can be used simultaneously: 4

Cooking zones with booster: 4

Appliance width (mm): 590  
Net weight (kg): 11.2  
Gross weight (kg): 13.0  
Residual heat indicator: Yes

age of control: Front  
Type of control: Touch control / Slider  
LED display - Red  
Main surface material: Glass ceramic  
Surface colour: Black Approval certificates: CE / UKCA

**Consumption and connection values:**

Electrical connection value (W): 7400

Voltage (V): 220-240

Frequency (Hz): 50; 60

Colour of unit: black

Energy source: Electric

Approval certificates: CE / UKCA Plug type: without plug

Number of cooking zones that can be used simultaneously: 4

Dimensions of the appliance (mm): 58 x 784 x 524  
Niche dimensions (mm): 52 x 750 x 500  
Dimensions of the packed appliance (mm): 95 x 840 x 600

Net weight (kg): 11.2

Gross weight (kg): 13.0