

Built-in wine cooler drawer

5WS614FF0

EG017915

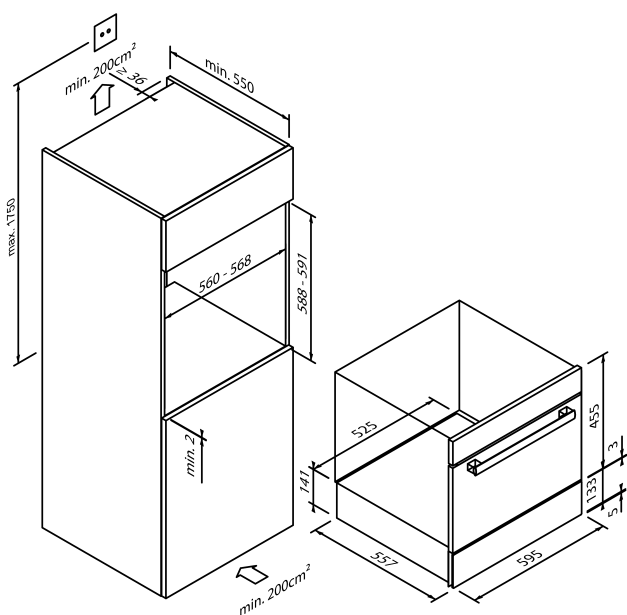

Design	
Colour	Black glass
Version	Built-in appliance for a 60 cm wide tall unit
Height (in cm)	14

Output & consumption	
Energy consumption per year (in kWh)	88
Total useful capacity (in litres)	13
Noise level (in dB A) re 1 pW	35

Operating comfort & equipment	
Operation	Touch Control
Door opening	Handleless / Push-to-open (electronic)
Display / Colour	Digital / White
Interior lighting	LED
UV protective glazing	•
Anti-vibration system	•
Acoustic door alarm	•
Telescopic pull-outs	•
Cushioned hinges	-

Refrigeration compartment	
Temperature zones	1
Temperature setting, upper zone	5°C - 20°C
Temperature setting, lower zone	-
Solid wood shelves	-
Capacity / bottles 0,75 litres each	5

Technical data	
Energy efficiency class	F
Fixed door technology / sliding door technology	- / -
Door hinge	-
Connected load	220 - 240 V
Fuse protection (in A)	0,8 A
Frequency (in Hz)	50 Hz
Plug type	Type F
Length of connection cable (in cm)	180 cm
Net weight (in KG)	16,0 kg
Gross weight (in KG)	19,0 kg
Dimensions of the packaged appliance (H x W x D)	21,0 x 68,0 x 66,0 cm
Appliance dimensions (H x W x D)	14,0 x 59,5 x 55,7 cm
Recess dimensions (H x W x D)	14,0 x 56,0 x 55,0 cm
EAN	4251003110296